

SERVICE INFORMATION LETTER

Subject: IGVA Sector Gear with Oversize D-Hole Creating Loose Fit with NHA

1. Planning

a. Effectivity

Wencor P/N	NHA P/N	NHA Description	ATA	Aircraft Application
3810119-2WE	381326-2-X 381364-1-X 3800298-1-X 381336-1 381388-1	Gas Turbine Power Unit (APU) Model GTCP331-200 & -250	49-22-11 49-22-13 49-22-61 49-23-49	A300-B4-600 Series A300-F4-600 Series A310-200 Series A310-300 Series B757-200 Series B757-200CB Series B757-200PF Series B757-300 Series B767-200 Series B767-300 Series B767-300F Series

b. Reason:

The D-shaped hole in the Wencor Inlet Guide Vane Assembly Sector Gear PN 3810119-2WE was manufactured oversize by .002” as shown below in Figure 1. The oversize condition will create a loose fit with the mating part and may lead to premature wear on the Inlet Guide Vane (IGV) stem, or other IGVA parts that operate in conjunction with the Sector Gear (see Figure 2).

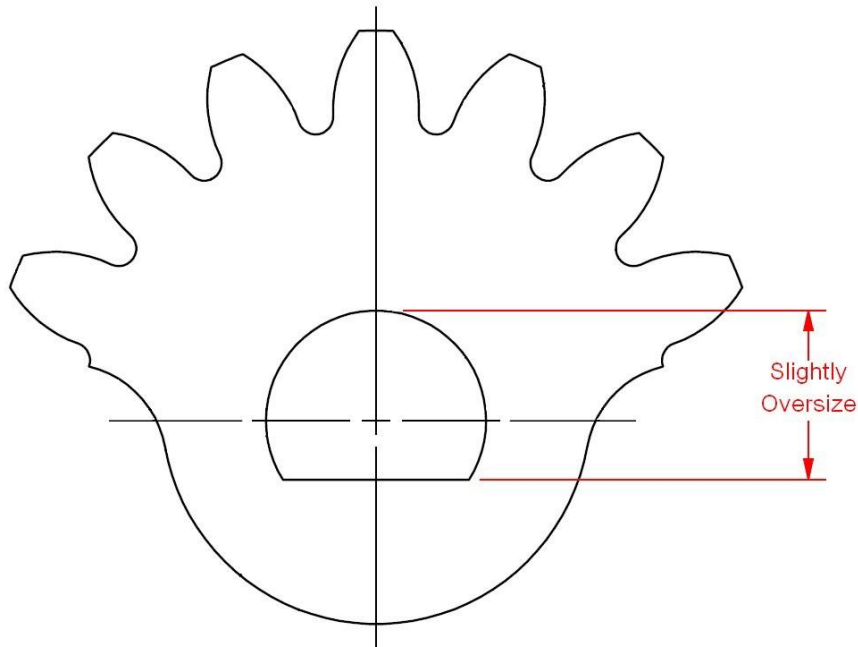

Figure 1, Sector Gear, Showing Oversize D-Shaped Hole

c. Background

Based upon a customer report of a tight installation problem, Wencor revised the Sector Gear design by adjusting the maximum D-shaped hole size up by .002" to prevent a possible interference condition with the mating IGV Vane stem. It was later discovered that the IGV Vane stem was the cause of the interference condition and the D-shaped hole size was re-designed larger than allowed per the OEM CMM. The re-designed Sector Gears were sold to customers and put into service.

The size of the Wencor Sector Gear D-shaped hole has subsequently been revised and is now equivalent to the OEM hole size limits. All Wencor Sector Gears purchased after July 2012 have the correct D-shaped hole size.

d. Safety

This oversize condition does not affect aircraft safety or change instructions for continued airworthiness.



1625 North 1100 West
Springville, UT 84663
801-489-2000

2. Recommended Action

a. Repair and Overhaul

For new Wencor Sector Gears that have not been installed, users can verify correct D-shaped hole size by measuring the hole as described in the OEM Component Maintenance Manual (CMM). Any Wencor Sector Gear D-shaped hole that is measured oversize shall be returned to Wencor for replacement.

For Wencor Sector Gears that have been installed, the user shall check the size of the D-shaped hole at the next shop maintenance/overhaul opportunity. Any Wencor Sector Gears that are within CMM limits can remain in service and any that are out of limits shall be removed and replaced according to the CMM.

3. Compliance

There is no required time frame for compliance of this SIL.

4. Material

Wencor Sector Gears that require replacement as a result of this Service Information Letter will be covered free of charge under the Wencor material warranty. If there are any questions regarding this Service Information Letter, please contact the applicable Wencor sales representative by calling 801-489-2000 or email: sales@wencor.com. For technical questions please contact Jon Bies at jbies@wencor.com.

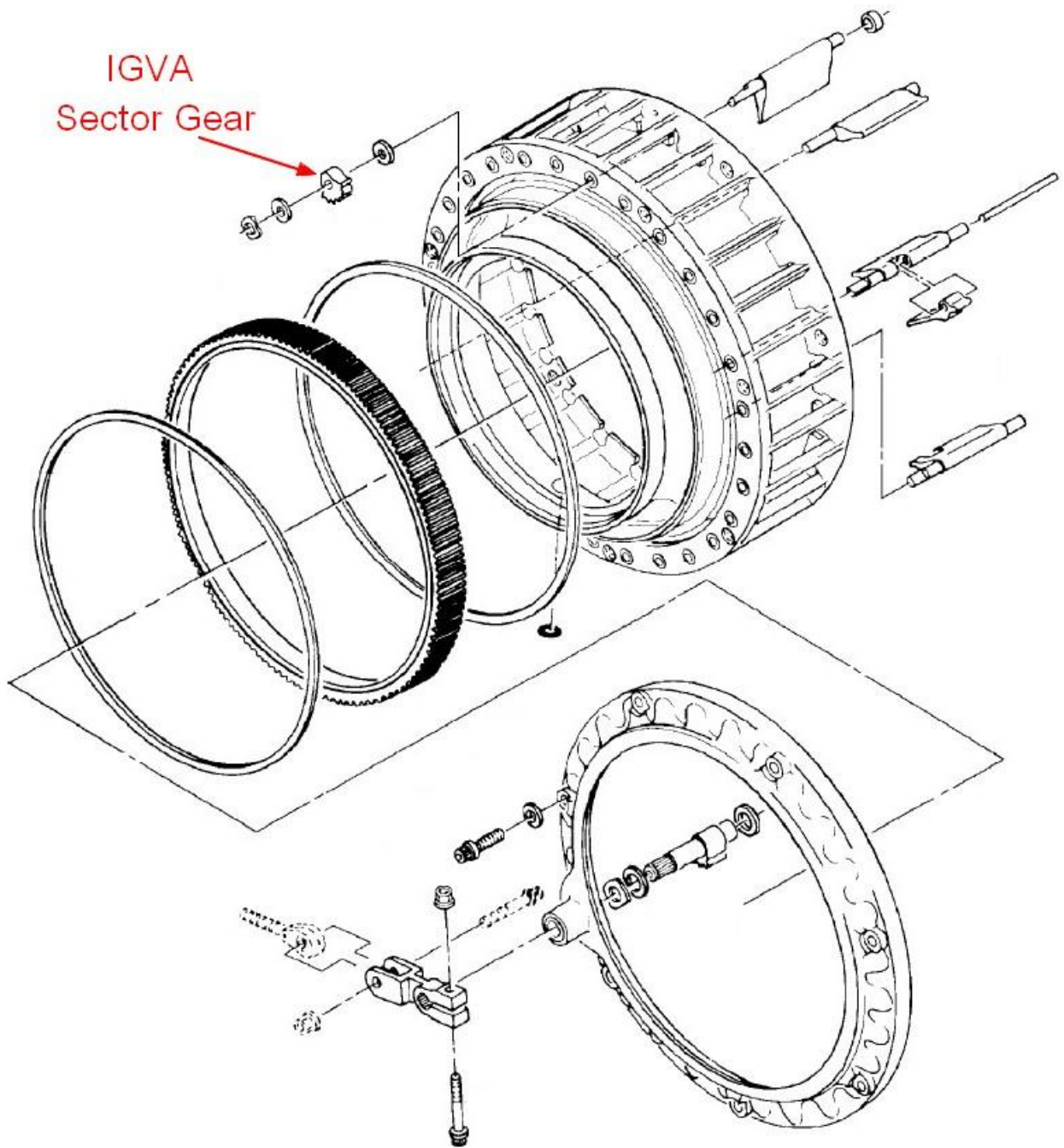

Figure 2, Sector Gear Shown in the Inlet Guide Vane Assy