

SERVICE INFORMATION LETTER

Subject: Center Shaft with damaged edge preventing proper installation.

1. Planning

a. Effectivity

Wencor P/N	NHA P/N	NHA Description	ATA	Aircraft Application
140N2700-5WA	140N2665 143N6100	Passenger Door Handle Mechanism	52-11-13-01	B757-200 B757-200F B757-300

b. Reason:

During installation of the Wencor Center Shaft PN 140N2700-5WA, a single customer discovered that an edge was slightly damaged as shown in Figure 1 below, and the damage prevented proper assembly into the NHA.

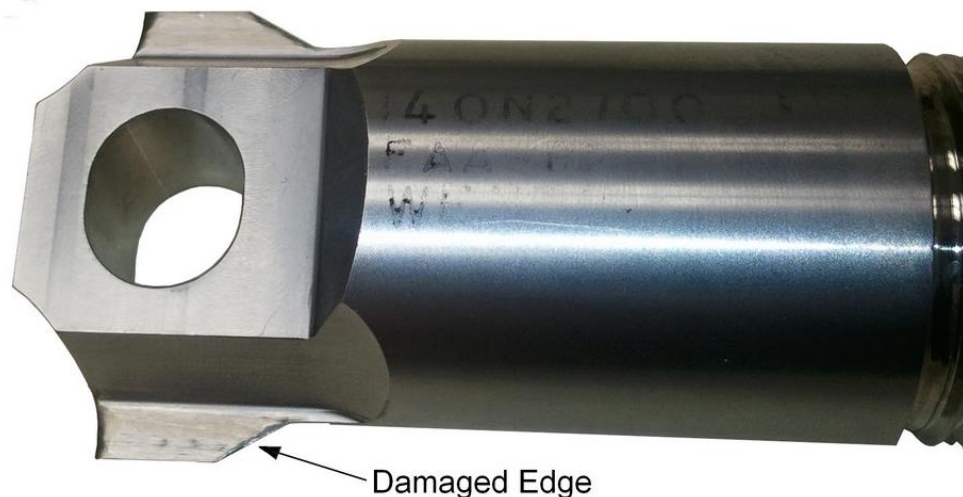

Figure 1, Wencor Center Shaft with Damaged Edge

Revision: Original
Date: May 13, 2013

Service Information Letter No: 130513-001
Page 1 of 3



A WENCOR GROUP Company

1625 North 1100 West
Springville, UT 84663
801-489-2000

c. Background

The source or cause of the damaged edge has not been conclusively determined, however the only effect of the damaged edge is displaced material that causes an interference with the mating features on the NHA (see Figure 2 below) thus preventing proper installation.

d. Safety

This condition does not affect aircraft safety.

2. Recommendations

Any Wencor Center Shaft that is currently uninstalled that has the condition described in this SIL should be returned to Wencor for replacement.

However, any Wencor Center Shaft that is currently installed and in-service that have the condition described in the SIL may remain in service at the discretion of the end user without any change in aircraft safety.

3. Compliance

There is no compliance time frame for this SIL.

4. Material

Wencor Center Shaft's that require replacement as a result of this Service Information Letter will be covered free of charge under the Wencor material warranty. If there are any questions regarding this Service Information Letter, please contact the applicable Wencor sales representative by calling 801-489-2000 or email: sales@wencor.com. For technical questions please contact Jon Bies at jbies@wencor.com.

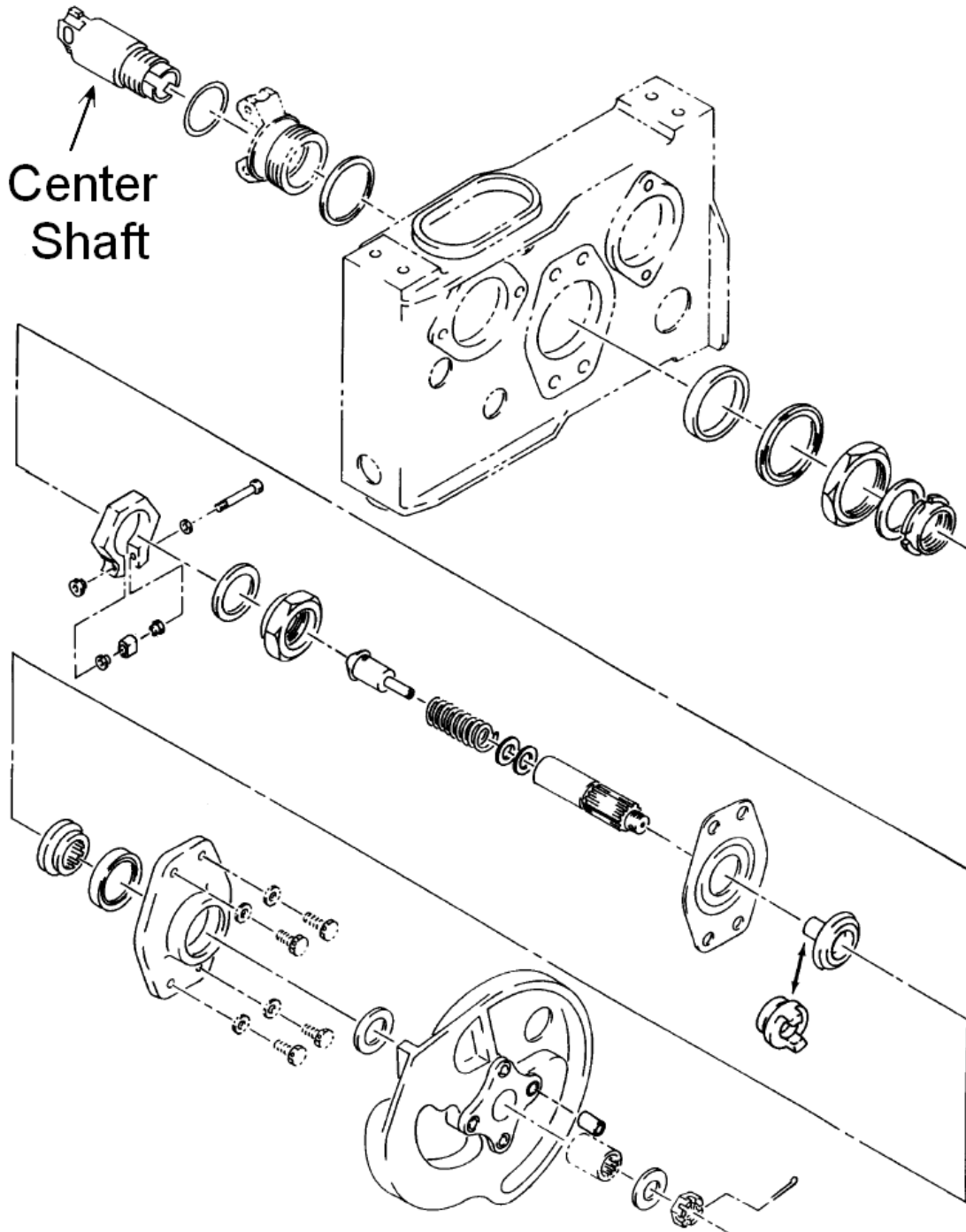

Figure 2, Exploded View of Center Shaft Installation

Revision: Original
Date: May 13, 2013

Service Information Letter No: 130513-001
Page 3 of 3